

*With Correction Slip No. 1, dt. 3.3.2005,  
Correction Slip no. 2 dt. 12.6.06 &  
Correction Slip no. 3 dt. 05.1.09*



भारत सरकार  
रेल मंत्रालय

रेलपथ गिट्टी  
की  
विशिष्टियां  
**SPECIFICATIONS  
FOR  
TRACK BALLAST**

**IRS-GE-1  
JUNE-2004**

भू.तकनीकी अभियांत्रिकी निदेशालय  
अनुसंधान अभिकल्प और मानक संगठन  
लखनऊ.२२६०११

## CONTENTS

	<b>Title</b>	<b>Page No.</b>
<b>1</b>	<b>Scope</b>	<b>1</b>
<b>2</b>	<b>Detailed Specifications</b>	<b>1</b>
<b>3</b>	<b>Conditions for submission of tender</b>	<b>3</b>
<b>4</b>	<b>Method of measurement</b>	<b>3</b>
<b>5</b>	<b>Sampling and Testing</b>	<b>4</b>

## ANNEXURES

(Test Methods based on relevant IS Codes)

<b>1</b>	<b>Aggregate Abrasion Value</b>	<b>6</b>
<b>2</b>	<b>Aggregate Impact Value</b>	<b>7</b>
<b>3</b>	<b>Water Absorption</b>	<b>8</b>

## SPECIFICATION FOR TRACK BALLAST

1. **SCOPE:** These specifications will be applicable for stone ballast to be used for all types of sleepers on normal track, turnouts, tunnels and deck slabs etc on all routes.

2. **DETAILED SPECIFICATIONS:**

### 2.1 GENERAL

2.1.1 **Basic Quality:** Ballast should be hard durable and as far as possible angular along edges/corners, free from weathered portions of parent rock, organic impurities and inorganic residues.

2.1.2 **Particle shape:** Ballast should be cubical in shape as far as possible. Individual pieces should not be flaky and should have generally flat faces with not more than two rounded/ sub rounded faces.

2.1.3 **Mode of manufacture:** Ballast for all BG main lines and running lines, except on 'E' routes but including 'E' special routes, shall be machine crushed. For other BG lines and MG/NG routes planned/sanctioned for conversion, the ballast shall preferably be machine crushed. Hand broken ballast can be used in exceptional cases with prior approval of Chief Track Engineer/CAO/C. Such approval shall be obtained prior to invitation of tenders.

On other MG and NG routes not planned/sanctioned for conversion hand broken ballast can be used for which no approval shall be required.

### 2.2 PHYSICAL PROPERTIES

2.2.1 Ballast sample should satisfy the following physical properties in accordance with IS:2386 Pt.IV-1963 when tested as per the procedure given in Annexure-I & II.

	BG, MG & NG(planned/sanctioned For conversion)	NG & MG(other than those planned for conversion)
Aggregate Abrasion value	30% Max.*	35% Max.
Aggregate Impact value	20% Max.*	30% Max.

\* In exceptional cases, on technical and/or economic grounds relaxable upto 35% and 25% respectively by CTE in open line and CAO/C for construction projects. The relaxation in Abrasion and Impact values shall be given prior to invitation of tender and should be incorporated in the Tender document.

2.2.2 The ‘**Water Absorption**’ tested as per IS 2386 Pt.III-1963 following the procedure given in Annexure III should not be more than 1%. This test however, *to be prescribed at the discretion of CE/CTE in open line and CAO/Con. For construction projects.*

## 2.3 SIZE AND GRADATION

### 2.3.1 Ballast should satisfy the following size and gradation:

- |    |                                 |  |
|----|---------------------------------|--|
| a) | Retained on 65mm Sq.mesh sieve  | 5% Maximum   |
| b) | Retained on 40mm Sq.mesh sieve* | 40%-60%  |
| c) | Retained on 20mm Sq.mesh sieve  | Not less than 98% for machine crushed<br>Not less than 95% for hand broken |

\* For machine crushed ballast only.

### 2.3.2 Oversize ballast

- i) Retention on 65mm square mesh sieve.

A maximum of 5% ballast retained on 65mm sieve shall be allowed without deduction in payment.

In case ballast retained on 65mm sieve exceeds 5% but does not exceed 10%, payment at 5% reduction in contracted rate shall be made for the full stack. Stacks having more than 10% retention of ballast on 65mm sieve shall be rejected.

- ii) In case ballast retained on 40mm square mesh sieve (machine crushed case only) exceeds 60% limit prescribed in 2.3.1 (b) above, payment at the following reduced rates shall be made for the full stack in addition to the reduction worked out at i) above.

- 5% reduction in contracted rates if retention on 40mm square mesh sieve is between 60% (excluding) and 65% (including).
- 10% reduction in contracted rates if retention on 40mm square mesh sieve is between 65% (excluding) and 70% (including).

- iii) In case retention on 40mm square mesh sieve exceeds 70%, the stack shall be rejected.

- iv) In case of hand broken ballast supply, 40mm sieve analysis may not be carried out. The executive may however ensure that the ballast is well graded between 65mm and 20mm size.

2.3.3 **Under Size Ballast:** The Ballast shall be treated as undersize and shall be rejected if-

- i) Retention on 40mm Sq. Mesh sieve is less than 40%.
- ii) Retention on 20mm square mesh sieve is less than 98% (for machine crushed) or 95% (for hand broken).

2.3.4 **Method of Sieve Analysis:**

- i) Sieve sizes mentioned in this specification are nominal sizes. The following tolerances in the size of holes for 65, 40 and 20mm nominal sieves sizes shall be permitted.  
65mm Square Mesh Sieve Plus Minus 1.5mm  
40mm Square Mesh Sieve Plus Minus 1.5mm  
20mm Square Mesh Sieve Plus Minus 1.0mm  
Mesh sizes of the sieves should be checked before actual measurement. The screen for sieving the ballast shall be of square mesh and shall not be less than 100cm in length, 70cm in breadth and 10cm in height on sides.
- ii) While carrying out sieve analysis, the screen shall not be kept inclined, but held horizontally and shaken vigorously. The pieces of ballast retained on the screen can be turned with hand to see if they pass through but should not be pushed through the sieve.
- iii) The percentage passing through or retained on the sieve shall be determined by weight.

### **3. CONDITIONS FOR SUBMISSION OF TENDER**

- 3.1 Each tenderer at the time of tendering shall submit the test report of Impact Value, Abrasion Value, Water Absorption Value from approved laboratories and the list of these laboratories shall be mentioned in the tender documents.
- 3.2 The tenderer shall also furnish an undertaking as incorporated in the tender document that the ballast supply at all times will conform to Specifications for Track Ballast as specified by Railway.

### **4. METHOD OF MEASUREMENT**

#### **4.1 Stack Measurement**

Stacking shall be done on a neat, plain and firm ground with good drainage. The height of stack shall not be less than 1m except in hilly areas where it may be 0.5m. The height shall not be more than 2.0m. Top width of stack shall not be less than 1.0m. Top of stack shall be kept parallel to the ground plane. The side slopes of stack should not be flatter than 1.5:1 (Horizontal : Vertical). Cubical content of each stack shall normally be not less than 30 cum in plain areas and 15 cum in hilly areas.

## 4.2 Wagon Measurement

- 4.2.1 In case of ballast supply taken by direct loading into wagons, a continuous white line should be painted inside the wagon to indicate the level to which the ballast should be loaded. The cubical content in cubic meter corresponding to white line should also be painted on both sides outside the wagon.
- 4.2.2 In addition to painted line, mentioned in para 4.2.1, short pieces of flats (cut pieces of tie bars or otherwise) with cubical contents punched shall be welded at the centre of all the four sides as permanent reference. In case the supply is taken in general service wagon, actual measurements will be taken.

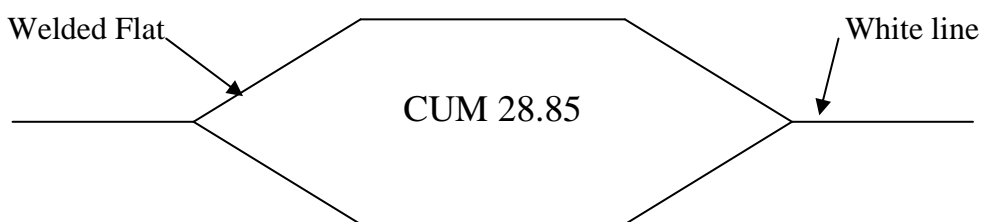

## 4.3 Shrinkage Allowance

Payment shall be made for the gross measurements either in stacks or in wagons without any deduction for shrinkage/voids. However, when ballast supply is made in wagons, shrinkage upto 8% shall be permitted at destination while verifying the booked quantities by the consignee.

## 5. SAMPLING AND TESTING

- 5.1 A minimum of 3 samples of ballast for sieve analysis shall be taken for measurement done on any particular date even if the numbers of stacks to be measured are less than three.
- 5.2 The test viz. Determination of Abrasion Value, Impact Value and Water Absorption should be got done through approved laboratories or Railway's own laboratories (List of these laboratories shall be mentioned in the tender document).
- 5.3 In order to ensure supply of uniform quality of ballast, the following norms shall be followed in respect of sampling, testing and acceptance.
- 5.3.1 On supply of the first 100 cum, the tests for size gradation, Abrasion value, Impact value and water absorption (if prescribed) shall be carried out by Railway. Further supply shall be accepted only after this ballast satisfies the specifications for these tests. Railway reserves the right to terminate the contract as per GCC at this stage itself in case the ballast supply fails to conform with any of these specifications.

### 5.3.2 Subsequent tests shall be carried out as follows

	Supply in stacks		Supply in wagons
	For stack of volume less than 100 cum	For stack of volume more than 100 cum	
a) Size and Gradation Tests.			
- No. of Tests	One for each stack.	One for each stack.	One for each wagon.
- Size of one sample	** 0.027 cum	** 0.027 cum for every 100 cum or part thereof.	** 0.027 cum
b) Abrasion Value, Impact Value and Water Absorption test @ Testing Frequency	One test for every 2000 cum		

\*\* This sample should be collected using a wooden box of internal dimensions 0.3m x 0.3m x 0.3m from different parts of the stack/wagon.

@ These tests shall be done for the purpose of monitoring quality during supply. In case of the test results not being as per the prescribed specifications at any stage, further supplies shall be suspended till suitable corrective action is taken and supplies ensured as per specifications.

The above tests may be carried out more frequently if warranted at the discretion of Railway.

5.3.3 All tests for Abrasion value Impact value and water absorption conducted subsequently to award of contract shall be done at Railway's cost.

**Aggregate Abrasion Value  
(Based on IS:2386 Part IV-1963)**

**1. Apparatus**

- 1.1 The abrasion test for track ballast shall be carried out using **Los-Angles Machine** as per fig.1.
- 1.2 The **abrasive charge** shall consist of 12 nos. cast iron or steel spheres approx. 48mm dia and each weighing between 390 and 445 gm ensuring total weight of charge as 5,000 ± 25gm.
- 1.3 **IS sieves** of sizes 50mm, 40mm, 25mm and 1.70mm.
- 1.4 **Drying Oven**

**2. Test Sample**

- 2.1 The test sample of 10,000gm shall consist of clean ballast conforming to the following grading:
  - Passing 50mm and retained on 40mm square mesh sieve 5,000 gm@
  - Passing 40mm and retained on 25mm square mesh sieve 5,000 gm@@ tolerance of ±2% permitted.
- 2.2 The sample shall be dried in oven at 100 – 110 °C to a constant weight and weighed (Weight 'A').

**3. Test Procedure**

The test sample and the abrasive charge shall be placed in the Los-Angeles abrasion testing machine and the machine rotated at a speed of 20-33 revolutions/minute for 1000 revolutions. At the completion of test, the material shall be discharged and sieved through 1.70mm IS sieve.

**4. Analysis and reporting of the Result**

- 4.1 The material coarser than 1.70mm IS sieve shall be washed, dried in oven at 100 - 110°C to a constant weight and weighed (weight B).
- 4.2 The proportion of loss between Weight "A" and Weight "B" of the test sample shall be expressed as a percentage of the original weight of the test sample. This value shall be reported as:

$$\text{Aggregate Abrasion Value} = \frac{A-B}{A} \times 100$$



**Aggregate impact value  
(Based on IS:2386 Part IV-1963)**

**1. Apparatus**

The apparatus shall consist of the following

- a) **Impact testing machine** conforming to IS:2386 part IV-1963 as per fig.2.
- b) **IS Sieve** of sizes 12.5mm, 10mm and 2.36mm.
- c) **A cylindrical metal measure** of 75mm dia & 50mm depth.
- d) **A tamping rod** 10mm circular cross section and 230mm length, rounded at one end.
- e) **Drying Oven**

**2. Test Sample**

2.1 The test sample shall be prepared out of track ballast so as to conform to following grading:

- Passing 12.5mm IS sieve                      100%
- Retention 10mm IS sieve                      100%

2.2 The sample shall be oven dried for 4 hours at a temperature of 100-110°C and cooled.

2.3 The measure shall be filled about one-third full with the prepared aggregate and tamped with 25 strokes of the tamping rod. A further similar quantity of aggregate shall be added and a further tamping of 25 strokes given. The measure shall finally be filled to overflowing, tamped 25 times and the surplus aggregate struck off, using and tamping rod as a straight edge. The net weight of the aggregate in the measure shall be determined to the nearest gm (weight 'A').

**3. Test Procedure**

3.1 The cup of impact testing machine shall be fixed firmly in the position on the base of the machine and the whole of the test sample placed in it and compacted by 25 strokes of the tamping rod.

3.2 The hammer shall be raised 380mm above the upper surface of the aggregate in the cup and allowed to fall freely on to the aggregate. The test sample shall be subjected to a total of 15 such blows, each being delivered at an interval of not less than one second.

**4. Analysis and Reporting of the result**

4.1 The sample shall be removed and sieved through 2.36mm IS sieve. The fraction passing through shall be weighed ( Weight 'B' ). The fraction retained on the sieve shall also be weighed ( Weight 'C' ) and if the total weight ( B+C ) is less than the initial weight ( Weight 'A' ) by more than one gm, the result shall be discarded and a fresh test made.

4.2 The ratio of the weight of the fines formed to the total sample weight shall be expressed as a percentage.

$$\text{Aggregate Impact Value} = (B/A) \times 100$$

4.3 Two such tests shall be carried out and the mean of the results shall be reported to the nearest whole number as the Aggregate Impact Value of the tested material.

**Water Absorption  
(Based on IS: 2386 Part III-1963)**

**1. Apparatus**

The apparatus shall consist of the following:

- a) **Wire Basket-** Perforated, electroplated or plastic coated, with wire hangers for suspending it from the balance.
- b) **Water tight** container for suspending the basket.
- c) **Dry soft Absorbent cloth** 75x45 cm size 2 nos.
- d) **Shallow Tray** of minimum 650 square cm area.
- e) **Air tight container** of capacity similar to basket.
- f) **Drying Oven.**

**2. Test Sample**

A sample of not less than 2000gm shall be used.

**3. Test Procedure**

- 3.1 The sample shall be thoroughly washed to remove finer particle and dust, drained and then placed in the wire basket and immersed in distilled water at a temperature between 22-32°C.
- 3.2 After immersion the entrapped air shall be removed by lifting the basket and allowing it to drop 25 times in 25 seconds. The basket and sample shall remain immersed for a period of  $24 \pm \frac{1}{2}$  hours afterwards.
- 3.3 The basket and aggregate shall then be removed from the water, allowed to drain for few minutes, after which the aggregate shall be gently emptied from the basket on to one of dry clothes and gently surface dried with the cloth transferring it to second dry cloth when the first will remove no further moisture. The stone aggregate shall be spread on the second cloth and exposed to atmosphere (away from direct sunlight) until it appears to be completely surface dry. The aggregate then shall be weighed (Weight 'A').
- 3.4 The aggregate shall then be placed in an oven at a temperature 100 - 110°C for 24 hours. It shall then be removed from oven, cooled and weighed (weight 'B').

**4. Analysis and Reporting of the Result**

$$\text{Water Absorption} = \{(A-B)/ B\} \times 100$$

- 4.1 Two such tests shall be made and individual and mean results shall be reported.

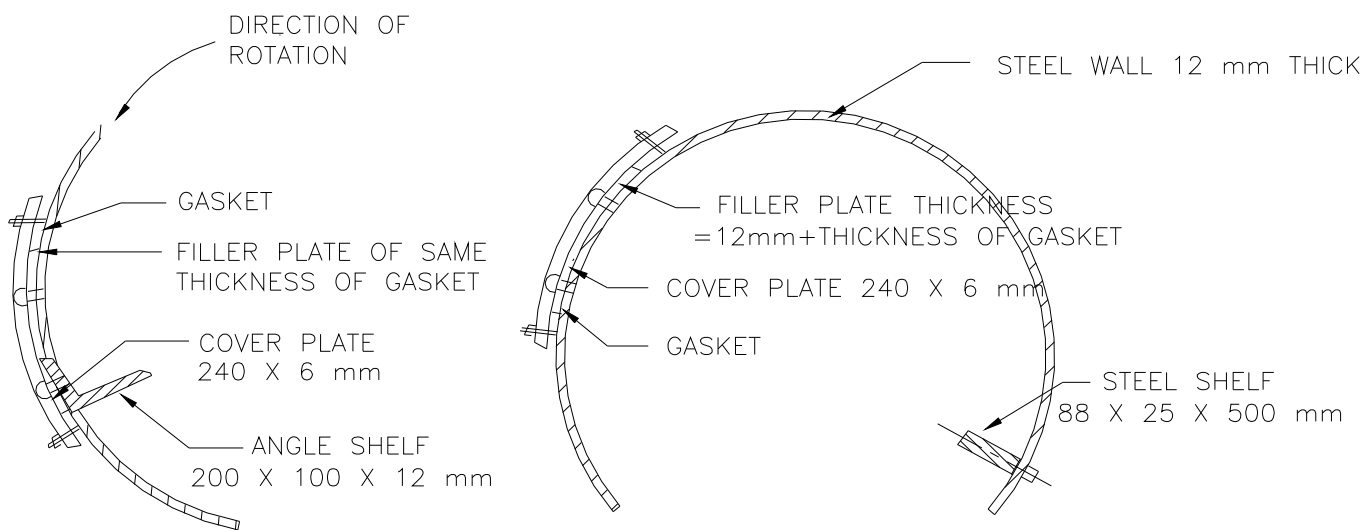

ALTERNATIVE DESIGN OF ANGLE SHELF

PREFERRED DESIGN OF PLATE SHELF AND COVER

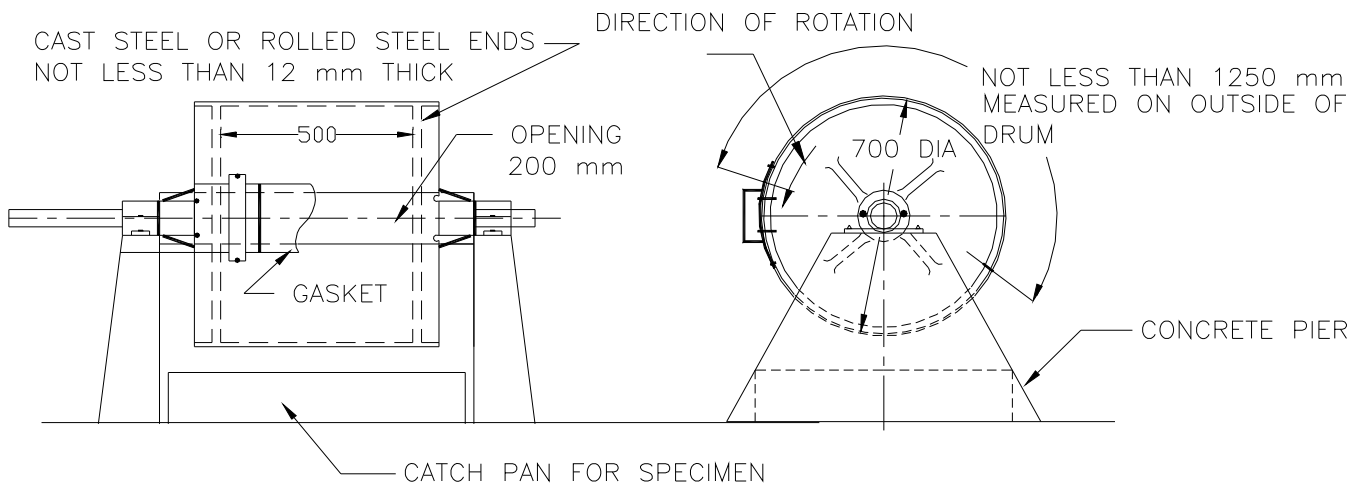

ALL DIMENSIONS ARE IN MILLIMETRES.

NOTE 1 -SHAFT BEARING WILL BE MOUNTED ON CONCRETE PIERS OR OTHER RIGID SUPPORTS.

NOTE 2 -SUGGESTED HORSE POWER FOR MOTOR IS NOT LESS THAN ONE.

### LOS ANGELES ABRASION TESTING MACHINE

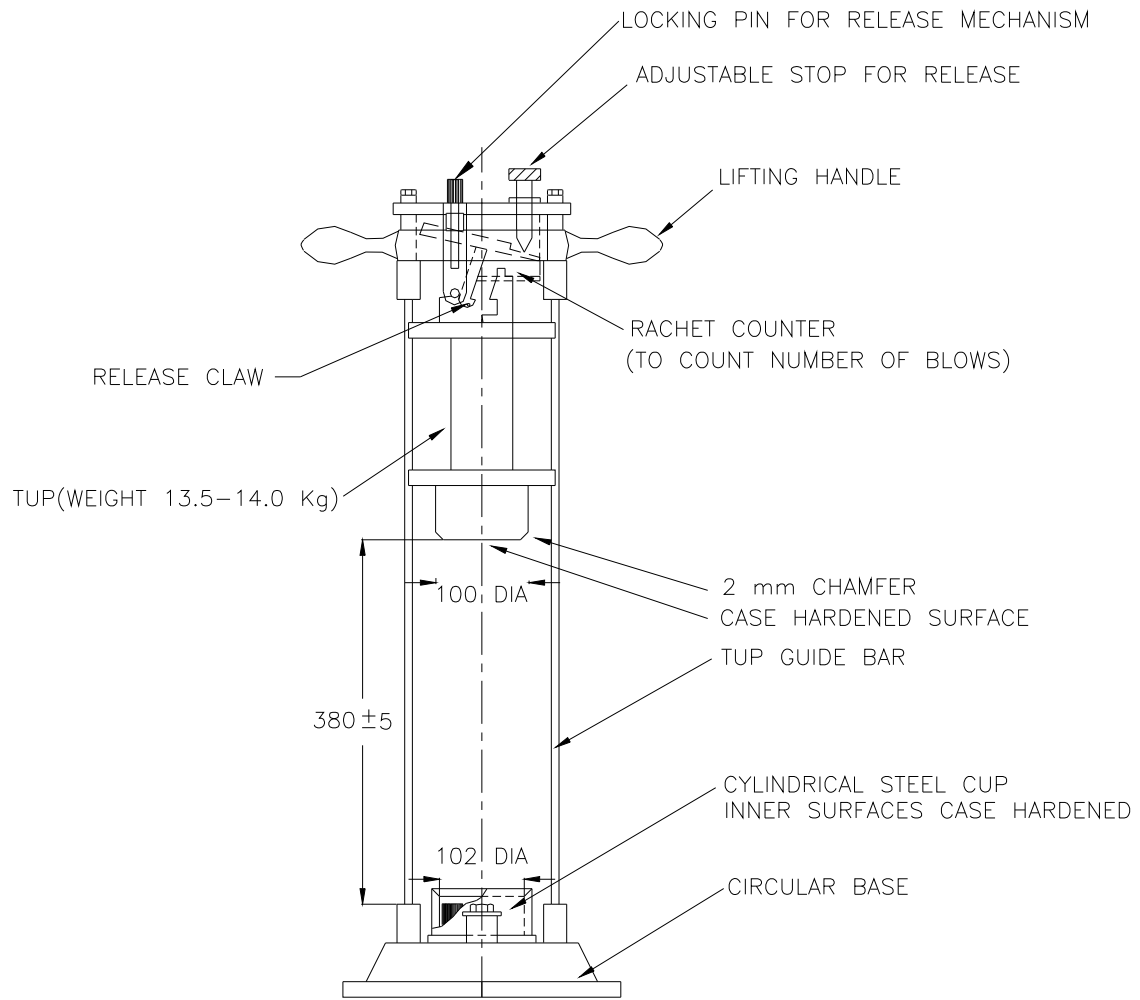

ALL DIMENSIONS ARE IN MILLIMETRES.

### AGGREGATE IMPACT TEST MACHINE

**Correction Slip No. 1**

**(“Specification of Track Ballast”, IRS-GE-1, June, 2004)**

Add a new para 2.3.1.1 as under :

**“In exceptional cases, where it is considered necessary on technical considerations, to reduce the maximum size of ballast for NG lines, CTE may modify the size & gradation of the ballast as defined above. In case of such modifications, provision given in para 2.3.2 to 2.3.4 below shall also be suitably modified. This will be finalized before invitation of tenders and should be incorporated in the tender documents.”**

Sd./- -  
(Nand Kishore)  
Executive Director /GE

## **Correction Slip No. 2**

*(“Specification of Track Ballast”, IRS-GE-I, June, 2004)*

Add a new para 5.3.4 as under:

**To Carry out Impact Test on ballast, a test sample of ballast pieces (about 5 kg in weight) of size 10 mm to 12.5 mm will be required. Appropriate care should be taken by the railways that ballast selected for breaking down to 10 mm to 12.5 mm size for Impact test should be random from the ballast supply to avoid any subjectivity in selection of test sample. Alternatively, the test sample in the recommended range of size be got manufactured along with the ballast in sufficient quantity required for this test.**

Sd./- -

(Alok Kumar)

Executive Director

Geotechnical Engineering

**Correction Slip No. 3**

To

**(“Specification of Track Ballast”, IRS-GE-1, June, 2004)**

Add a new para2.2.2.1 as under:

**“The power of relaxing for water absorption limit should be delegated to CTE in open line/CAO on construction for specified areas. However, maximum water absorption in any case should not be allowed more than 2.5%.”**

Sd./- -

(जे. सी. परिहार)

वरिष्ठ कार्यकारी निदेशक/भू-तकनीकी इंजीनियरी